

Referencia: 30024

## Arqueta Endesa A2 H=150 (62x117x150)

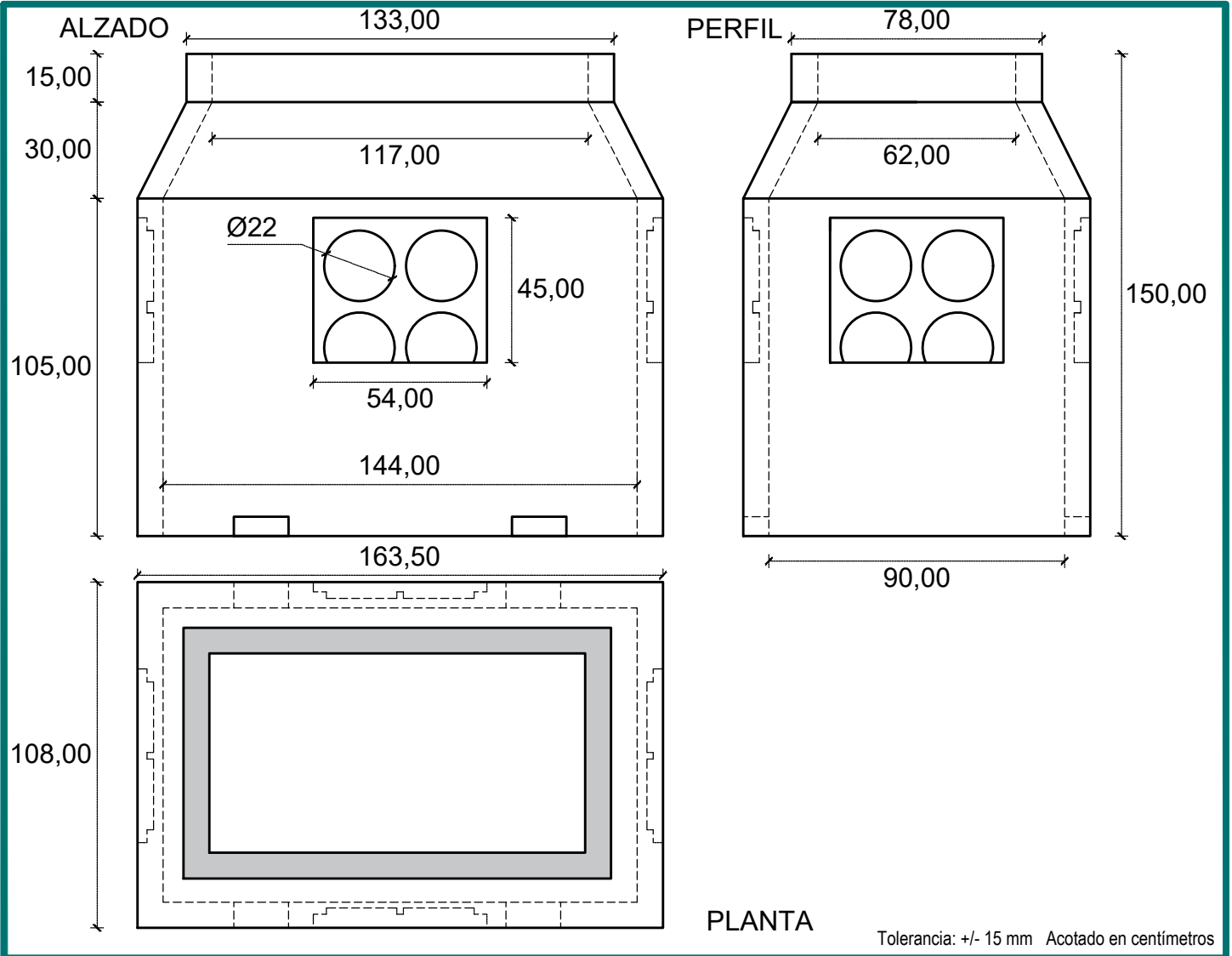

Uso: electricidad

Medidas	Interior		Exterior		Altura	Ventana	Peso
	Ancho	Largo	Ancho	Largo			
Superior	117	62	133	78	150	4 ventanas	1300 kg. (aproximado)
Base	144	90	163,5	108		Ø22	

Hormigón	HM-25
Cemento	CEM I 52,5 R
Áridos	Calizos

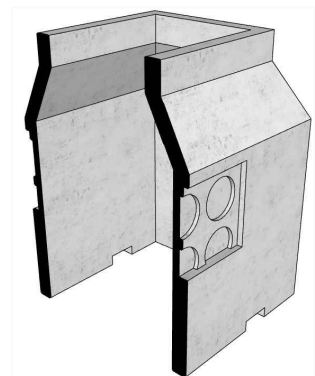
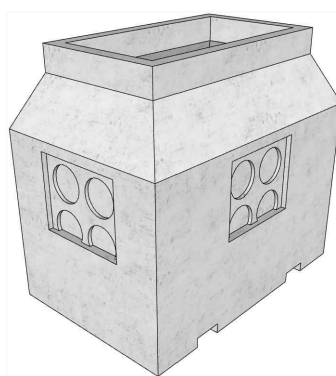
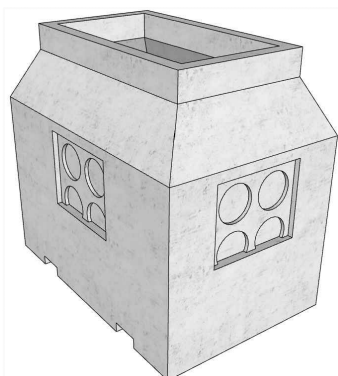

SECCIÓN